

Product Data Sheet DiamondJet Gas fuel HVOF Spray Guns

The most popular family of gas fueled HVOF spray guns worldwide, coatings applied using a DiamondJet™ spray gun are of very high quality and suitable for some of the toughest coating applications. Moreover, DiamondJet offers a lot of flexibility – customers can choose from a wide range of fuel gases, a choice of water or air cooled air caps and a choice of machine-mounted and hand-held gun versions.

The DiamondJet family of spray guns for HVOF has been developed to produce high integrity coatings of metals, alloys, superalloys and carbides. Coatings sprayed with a DiamondJet gun exhibit high density, low oxide content, superior microhardness and high adhesion with excellent machinability.

DiamondJet guns can be supplied with a water-cooled front section, which allow the gun to produce higher particle velocities, maximizing coating substrate and interparticle bonding. In general, water-cooled DiamondJet guns also have higher coating densities, higher hardness and lower oxide content. For mission critical applications and applications where service life must be maximized, the use of the water-cooled DiamondJet gun is strongly recommended.

Customers can choose from a variety of fuel gases to use with their DiamondJet guns, depending on gas availability, cost and coating quality required.

Machine-mount gun configurations are available for use with automated HVOF thermal spray systems as well as hand-held models, which may be used with manual systems.

Oerlikon Metco's DiamondJet series guns are designed and engineered with safety as an important element. Through extensive research and development, coupled with many years of experience, Oerlikon Metco has forged a system of reliable, safe HVOF spray equipment, processes and procedures. When safety recommendations and specifications are followed, Oerlikon Metco's equipment can be utilized with complete confidence.

CE versions of DiamondJet guns meet all safety requirements for European installations and operations, when ordered with a safety handle.

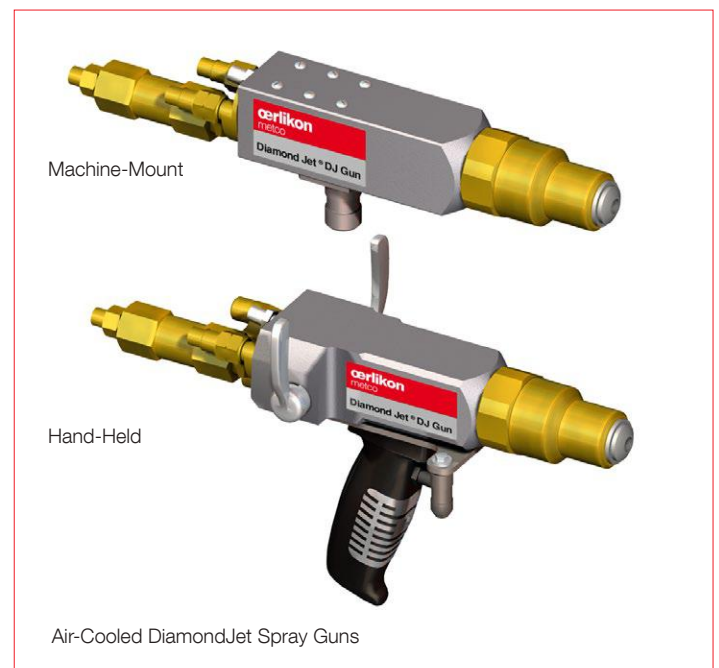
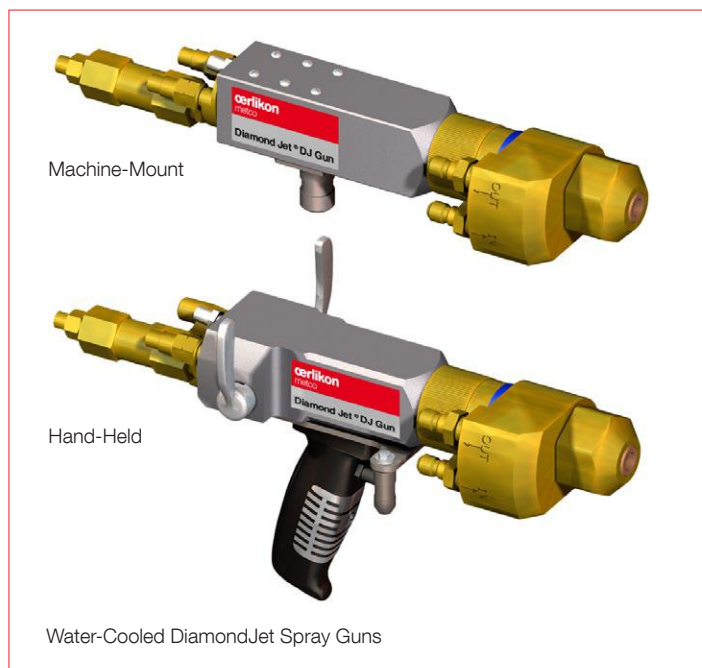

1 General Description

The DiamondJet process uses oxygen, fuel gas and air to produce a high pressure annular flame, which provides uniform heating of the axially introduced powder spray material. The gas stream is accelerated through a converging/diverging nozzle to supersonic speeds. The gas stream propels the powder particles towards the substrate. Individual particles deform plastically upon impact, tenaciously bonding the coating to the substrate. These coatings are very dense, with low porosity, predictable chemistries and fine, homogeneous microstructures. The axial powder injection focuses the coating material within the center of the flame, eliminating coating material buildup on the walls of the extended air cap and minimizing wear.

DiamondJet guns offer efficient operation, using less process gas compared to other HVOF spray guns. The standard, water-cooled guns consume minimal quantities of water, with only potable (drinking water) quality required at line pressures as low as 2.76 bar (40 psi).

Material spray rates, depending on gun configuration and material applied, can be as high as 150 g/min (20 lb/h), thus reducing spray times.

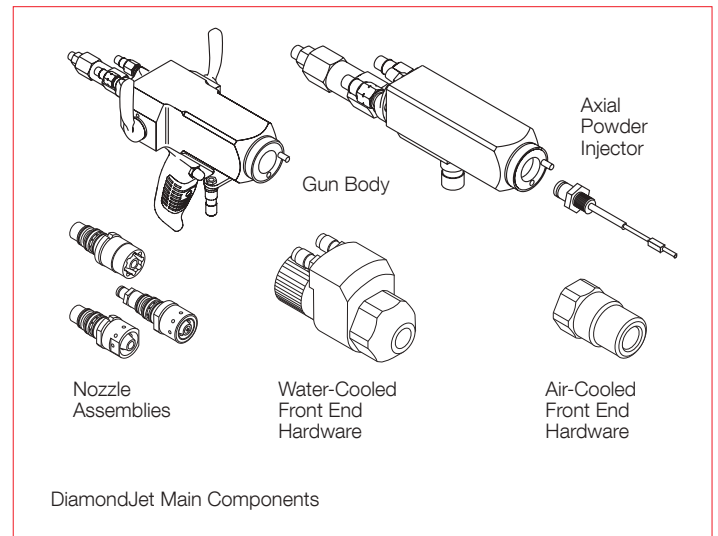

1.1 DiamondJet Gun Models

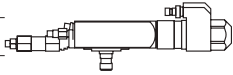
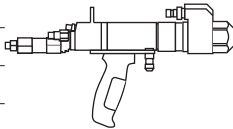
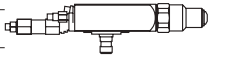
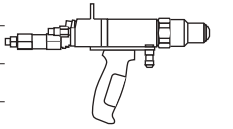
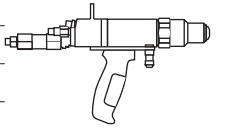
Model No.	Fuel Gas	CE Conformant					
2600DJM	Hydrogen	Yes		Machine-Mount	Water-Cooled		
2700DJM	Natural Gas, Ethylene, Propane, Propylene	Yes					
3600DJM ^a	Hydrogen	Yes					
2600DJH	Hydrogen	No		Hand-Held			
2600DJHE	Hydrogen	Yes ^c					
2700DJH-NG	Natural Gas	No					
2700DJHE-NG	Natural Gas	Yes ^c					
2700DJH	Propane, Propylene	No		Machine-Mount	Air-Cooled		
2700DJHE	Propane, Propylene	Yes ^c					
8ADJM	Hydrogen	Yes					Hand-Held
9ADJM	Propane, Propylene	Yes					
1050DJM ^b	Propane	Yes					
8ADJH	Hydrogen	No					
8ADJHE	Hydrogen	Yes ^c		Hand-Held			
9ADJH	Propane, Propylene	No					
9ADJHE	Propane Propylene	Yes ^c					
1050DJH ^b	Propane	No					
1050DJHE ^b	Propane	Yes ^c					

^a Long barrel configuration increases coating material dwell time for spraying coarse carbide or MCrAlY materials.

^b High spray rate configuration

^c Hand-held CE-conformant guns require the purchase of a SH or SHA Safety Handle for Certificate of Incorporation.

2 Features and Benefits

Effective

- Produces superior coatings for wear, corrosion and other surface functions that resist the harshest of service conditions.
- Coatings are very dense, low in oxides, high hardness, low residual stress within the coating structure.
- Coatings have very high bond strengths, up to 83 MPa (12,000 psi).
- Relatively cool process, allows coating of thin-walled components.
- Choice of fuel gases and gun configurations to suit application, economics and quality requirements.
- Thick coatings of up to 6.3 mm (0.25 in) are possible for restoration applications.

Efficient

- Smooth 'as-sprayed' surface finishes can be used as for many applications, and reduces processing when post-coat machining is necessary.

- Surfaces can be machined to high finishes and tight dimensional tolerances.
- Rugged, reliable design eliminates backfire.
- Easy to maintain with modular gun hardware that is simple to remove and replace without additional tools.
- Simple powder feed start and stop on hand-held gun using built-in handle trigger.
- Gun-mounted valve core actuator lever on hand-held models easily starts and stops the flow of process gases.

Economical

- Low process gas consumption compared to other HVOF spray guns.
- Water consumption for water-cooled guns is minimal, with only potable water quality required.
- Axial powder feed eliminates coating material buildup on the extended air cap, increasing gun service life.

3 Accessories and Options

Oerlikon Metco offers a variety of options that allow configuration of the DiamondJet family of guns for use in a wide number of coating applications and to suit specific production requirements. These include hose packages, and gun rebuild hardware kits. Customers should choose the correct parts for their specific gun configuration, coating application and spray requirements. Please refer to the DiamondJet Gun reference manual for a complete list of optional parts and spare parts.

Extension modules: Optionally available DJT series extension modules are available for DiamondJet guns that permit coating of interior bore diameters and surfaces. Please refer to

the DJT-2 / DJT-2M Extension Module product data sheet for additional information.

SHA Safety Handle Complete / SHA Safety Handle: Safely shuts off the gun should it slip from the operator's hand. Operation of the safety handle requires the Metco VB Shutoff Valve Box or a properly configured shutoff valve box supplied by others. A CE Certificate of Incorporation is provided with either kit:

- SHA: Includes the SH Safety Handle, VB Shutoff valve box and connecting hose.
- SH: Safety Handle only, for connection to an appropriate gas shutoff assembly supplied by others.

4 Technical Data

4.1 Dimensions

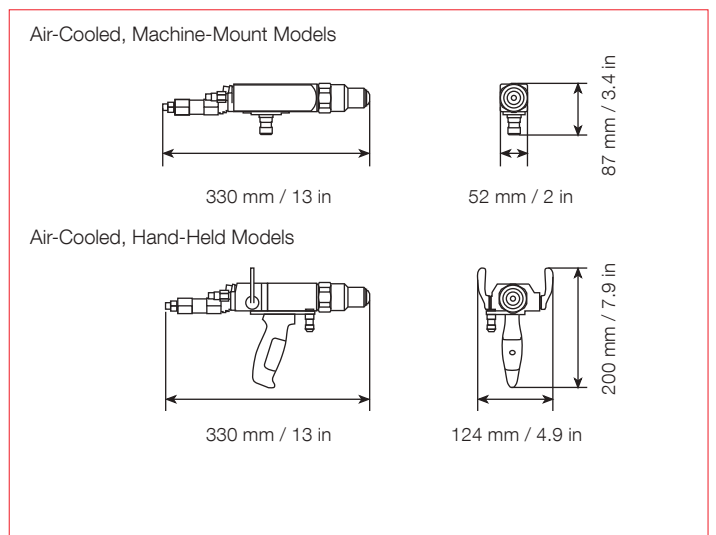
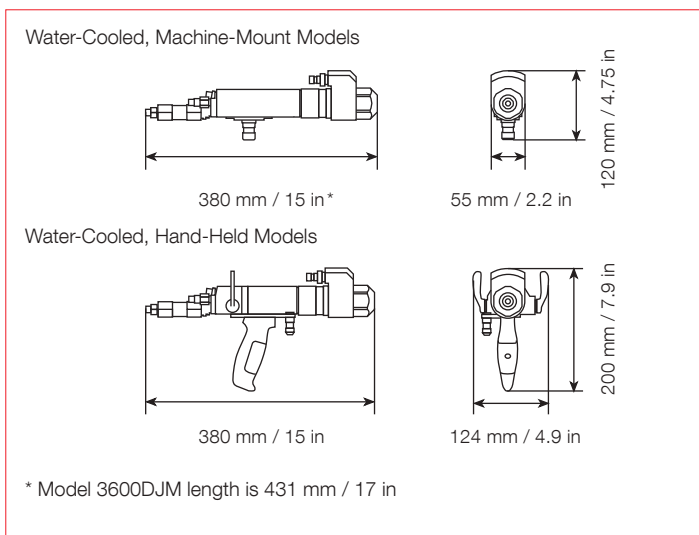

4.2 Specifications

General Specifications			Water-Cooled Gun Models		Air-Cooled Gun Models	
Gas Velocity			2140 m/s	7000 ft/s	1373 m/s	4500 ft/s
Combustion Pressure			6.9 bar	100 psig	3.8 bar	55 psig
Total Heat Output			113 kW	385000 Btu/h	113 kW	385000 Btu/h
Cooling Capacity ^a			8.8 kW	30000 Btu/h	–	–
Exhaust Flow		Minimum	140 m ³ /min	5000 ft ³ /min	140 m ³ /min	5000 ft ³ /min
Weight		Machine-Mount	3.4 kg	7.5lb	1.7 kg	3.7 lb
		Hand-Held	4.1 kg	9.0 lb	2.4 kg	5.2 lb
Process Gases ^b						
Fuel Gas						
Hydrogen	H ₂	Pressure	9.7 bar	140 psig	9.7 bar	140 psig
		Flow	730 NLPMP	1670 SCFH	730 NLPMP	1670 SCFH
Methane	CH ₄	Pressure	7.6 bar	110 psig	–	–
		Flow	202 NLPMP	460 SCFH	–	–
Ethylene	C ₂ H ₄	Pressure	7.2 bar	105 psig	–	–
		Flow	130 NLPMP	300 SCFH	–	–
Propylene	C ₃ H ₆	Pressure	6.9 bar	100 psig	5.5 bar	80 psig
		Flow	88 NLPMP	200 SCFH	88 NLPMP	200 SCFH
Propane	C ₃ H ₈	Pressure	6.2 bar	90psig	4.8 bar	70psig
		Flow	88 NLPMP	200 SCFH	88 NLPMP	200 SCFH
Oxygen	O ₂	Pressure	12 bar	170 psig	10.5 bar	150 psig
		Flow	307 NLPMP	700 SCFH	307 NLPMP	700 SCFH
Carrier Gas						
Nitrogen	N ₂	Pressure	12 bar	175 psig	12 bar	175 psig
		Flow	18 NLPMP	40 SCFH	18 NLPMP	40 SCFH
Air Requirements						
Pressure			7.2 bar	105 psig	5.2 bar	75 psig
Flow			439 NLPMP	1000 SCFH	439 NLPMP	1000 SCFH
Quality			Clean, dry and oil free		Clean, dry and oil free	
Water Requirements						
Pressure		Minimum	2.8 bar	40 psi	–	–
Flow		Minimum	9.5 l/min	2.5 gal/min	–	–
Inlet Temperature		Maximum	24 °C	75 °F	–	–
Quality			< 30 µS potable		–	–
Compatibility						
Controllers		Machine-Mount	MultiCoat HVOF, MultiCoat Pro HVOF, DJC, DJCEH		MultiCoat HVOF, MultiCoat Pro HVOF, DJC, DJCEH	
		Hand-Held	DJF with DJFEW		DJF	
Powder Feeders		Machine-Mount	SinglePro, Twin/Single 220-AH, Twin/Single 120-AH, 9MP-DJ, 9MPE-DJ, 9MPE-DJ-CL-20, 5MPE-HP		SinglePro, Twin/Single 220-AH, Twin/Single 120-AH, 9MP-DJ, 9MPE-DJ, 9MPE-DJ-CL-20, 5MPE-HP	
		Hand-Held	9MP-DJ, 9MPE-DJ, 5MPE-HP		9MP-DJ, 9MPE-DJ, 5MPE-HP	

^a Heat loss to water

^b Minimum pressure for the spray gun. Some system platforms, particularly those using mass flow control, may require higher minimum pressures.

Information is subject to change without prior notice.

DSE-0026.4 – DiamondJet Guns

© 2020 Oerlikon Metco

oerlikon
metco

www.oerlikon.com/metco
info.metco@oerlikon.com